



---

**300 Series Propellers Owner's Manual**  
(Version 17: Jan 2024)

---



**WHIRL WIND PROPELLERS CORP**  
1800 Joe Crosson Drive, Ste C  
El Cajon, CA 92020  
PHONE: 619-562-3725  
FAX: 619-562-4475  
Website: [whirlwindpropellers.com](http://whirlwindpropellers.com)  
Email: [wwpc@whirlwindpropellers.com](mailto:wwpc@whirlwindpropellers.com)

**WARNING!** Operation of this propeller over maximum RPM is strictly prohibited and may result in a catastrophic structural failure of the propeller system. Any type of structural failure may result in death or severe bodily injury. Refer to your propeller data sheet for Maximum RPM.

**WARNING!** Governor MAXIMUM pressure relief is 330 psi! Recommended governor model is Jihostroj P-920-032/A with 310 to 330 psi pressure relief valve.

*Whirl Wind propellers are experimental class and are not subject to any Federal Aviation Administration regulations. The operator acknowledges that these are experimental propellers and agrees to assume all risk in operating them on an experimental aircraft or any other machine. Any and all information in the owner's manual, service letters and other documentation are suggestions only and may not apply to an operator's specific application.*

# Table of Contents

1.	Introduction .....	4
1.1	Propeller Identification .....	4
1.2	Applicable Propellers .....	4
1.3	Propeller Specs and Applicable Engines.....	5
2.	Overview .....	5
2.1	Description .....	5
2.2	Construction.....	5
2.3	Standard Configuration.....	6
2.4	Required Lycoming SAE-2 Flange & Drive Lug Dimensions .....	7
3.	Installation Instructions .....	8
3.1	Propeller and Spinner Installation.....	8
3.2	Governor Installation.....	9
4.	Inspections and Operation.....	10
4.1	First Run-Up .....	10
4.2	Over-speed Warning.....	12
4.3	Dynamic Balancing .....	13
4.4	Blade Tracking.....	13
4.5	Preflight Check .....	13
4.6	First Flight .....	13
4.7	50-Hour Inspection .....	14
4.8	Teardown Inspection .....	14
5.	Vibrations and Troubleshooting .....	15
6.	Transfer of Ownership .....	16
7.	Limited Warranty.....	17
8.	Propeller Logbok.....	18

# 1. Introduction

## Congratulations on your propeller purchase from Whirl Wind Propellers!

To ensure many hours of trouble free operation of your new Whirl Wind propeller, please read and follow the operation and maintenance recommendations in this manual.

The Whirl Wind 300 Series propeller is a composite constant speed hydraulically controlled propeller (pressure to increase pitch). This constant speed propeller will automatically adjust blade pitch angle to maintain the selected engine RPM setting. A single acting piston (inside the hub) powered by engine oil changes the blade pitch. Oil pressure is adjusted and regulated by the engine driven governor.

### 1.1 Propeller Identification

Constant Speed Propeller Naming Convention:

Example Name: 300-3B(6)-A/B-77-S-R

300 -	3B(6) -	A	/B	-77	S	R
1 -	2 -	3	/4	-5	-6	-7

Hub
Blades

**Hub:**

1. Hub Series
2. Number of Blades (Hub Rev Number)
3. Flange: A = SAE-2 1/2", B = SAE-2 7/16"

**/Blade:**

4. Blade Style:
5. Diameter (inches) in the Intended Hub
6. C = Counter-Weight, S = Standard, Non Counter-Weighted
7. Rotation R = Right-Hand\*\*, L = Left-Hand

\*\* Right-hand rotation is clockwise when viewed from behind the aircraft

Constant Speed Propeller Naming Convention:

Example Propeller Name: 300-3B/A-72

300 -	3B -	/A	-72	
1 -	2 -	/4	-5	-6

Hub
Blades

**Hub:**

1. Hub Series
2. Number of Blades

**/Blade:**

4. Blade Style:
5. Diameter (inches) in the Intended Hub
6. C = Counter-Weighted, [Blank] or S = Standard

### 1.2 Applicable Propellers

This Owner's Manual is applicable to the following hub models:

**300-3B-A** thru **300-3B(6)-A**, and **300-3B-B** thru **300-3B(6)-B**

This Owner's Manual is applicable to the following blade models:

The "A" blade is a 70" or 72" RV style designed for high speed application.

The "B" blade is a 77" or 79" RV style designed for high speed application on a Lycoming IO-540 Engine.

## 1.3 Propeller Specs and Applicable Engines

Table 1

Propeller System:	300-3B/A-70	300-3B/A-72	300-3B/B-[77 or 79]-S-R
<b>Lycoming Engines: [Max Compression]</b>	(I)O-320 (9.6:1 Max Compression) (I)O-360 (Straight Valve with 8.5:1 Max Compression) (I)O-375 (Counter-Weighted with 9.6:1 Max Compression) (I)O-390 (9.6:1 Max Compression)	(I)O-320 (9.6:1 Max Compression) (I)O-360 (Straight Valve with 8.5:1 Max Compression) (I)O-375 (Counter-Weighted with 9.6:1 Max Compression) (I)O-390 (9.6:1 Max Compression)	(I)O-540 (Straight Valve with 9.6:1 Max Compression)
<b>Max RPM</b>	2700	2700	2700
<b>Weight:</b>	36 lb	36 lb	42 lb
<b>Tear Down Inspection:</b>	500 Hours	500 Hours	500 Hours
<b>Governor:</b>	Pressure to increase pitch (Max pressure 330 psi)	Pressure to increase pitch (Max pressure 330 psi)	Pressure to increase pitch (Max pressure 330 psi)

## 2. Overview

### 2.1 Description

Performance & Quality. This 300 Series propeller has been designed to maximize the performance of your airplane. This propeller delivers exceptional performance for the modern day sport aircraft. The exceptional performance is derived from advanced engineering developments, including the use of our latest airfoils.

#### Applicable Engines (150-270 hp)

Blade Style	Prop Diam.	Engine	Max Compression	Max RPM
A	70"-72"	(I)O-320	9.6:1	2700
A	70"-72"	(I)O-340	9.6:1	2700
A	70"-72"	(I)O-360	8.5:1 STRAIGHT VALVE!	2700
A	70"-72"	(I)O-370/375	9.6:1 COUNTERWEIGHTED!	2700
A	70"-72"	(I)O-390	9.6:1	2700
B	77"-79"	(I)O-540	9.6:1 STRAIGHT VALVE!	2700

Whirl Wind has made significant developments in the construction of the carbon composite propeller blades ensuring a strong, light and durable propeller system. The blade twist has been optimized for maximum performance and the wide chord allows for more low-speed thrust and braking on long down lines. The 300 Series propeller is a hydraulically controlled constant speed propeller, pressure to increase pitch. The propeller will go to fine pitch in case of oil pressure loss which could create an engine over-speed condition.

### 2.2 Construction

The 300 Series propeller blades are constructed from advanced thermoset composite materials. Each blade is equipped with a nickel leading edge erosion shield to protect the blade leading edge from debris damage. The 300 Series System includes: propeller, spinner, and all hardware needed for installation. The 300 Series hub is CNC machined from aerospace grade aluminum-6061, which is then shot peened and anodized. The hub blade sockets are equipped with ball bearings to ensure smooth pitch change of the blades throughout the life of the propeller system. This propeller can be flown in rain and off unimproved airstrips.

### **2.3 Standard Configuration**

This 300 Series propeller is a standard, non-aerobatic hydraulically controlled propeller system. The hub was designed to be mounted on a Lycoming engine flange with two flush drive lugs (see figures 1 and 2 on page 2-3) Oil pressure is required for high blade pitch (low RPM). In the event of engine oil pressure loss or governor failure, the propeller will return to flat pitch and may over-speed which can cause CATASTROPHIC FAILURE. If propeller over-speed occurs, the throttle must be retarded immediately to avoid structural propeller failure and damage.

## 2.4 Required Lycoming SAE-2 Flange & Drive Lug Dimensions

**For O-360:** *Four* Drive Lugs Extend 0.180" - 0.200" From Surface of Flywheel & *Two* flush drive lugs

Drive Lug OD: 0.75"  
Drive Lug Threads: 1/2"- 20

**For O-320:** *Four* or *Six* drive lugs can extend up to 0.480" from Surface of Flywheel

Drive Lug OD: 0.625"  
Drive Lug Threads: 7/16"- 20

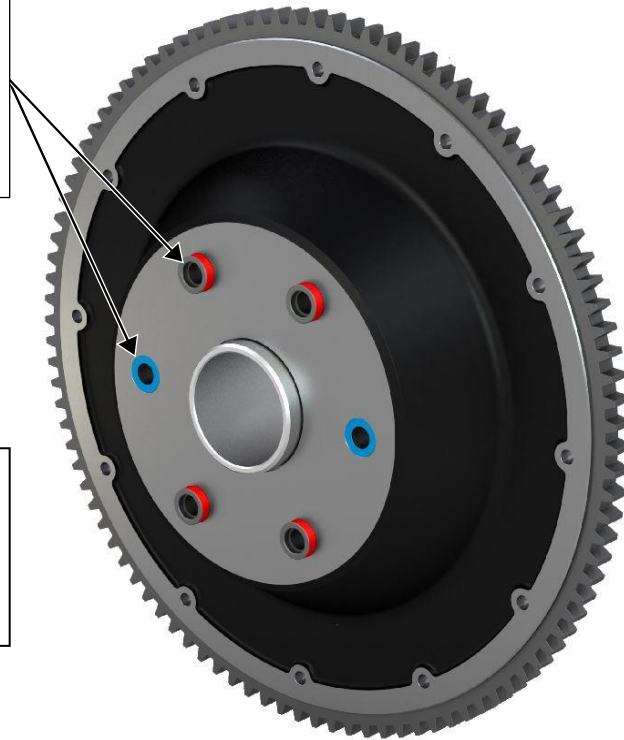

Figure 1

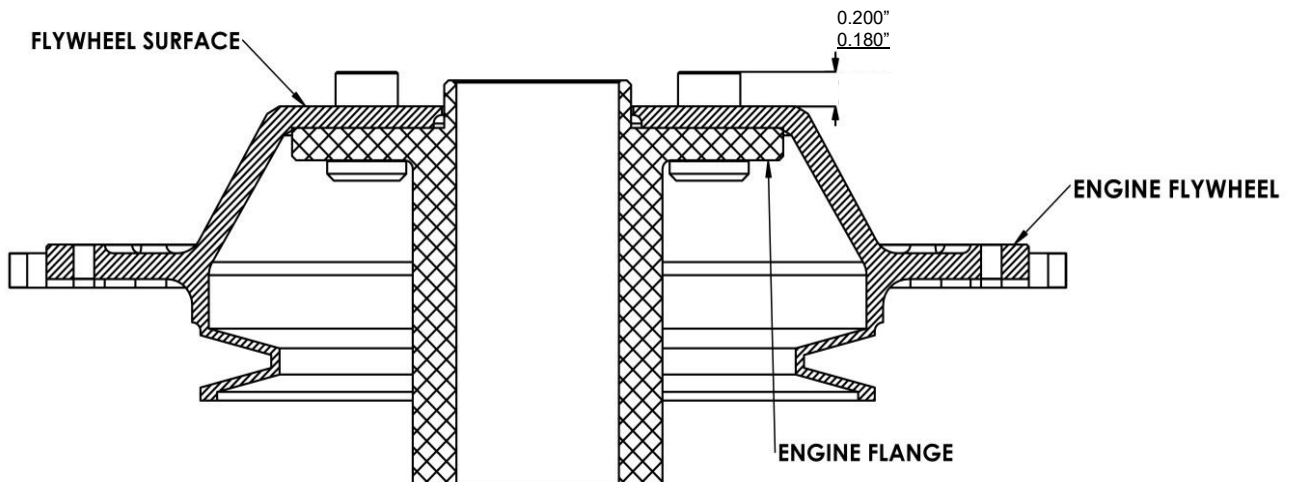

Figure 2

**NOTE: MINIMUM BOLT THREAD ENGAGEMENT OF 0.600"  
THE BOLT MAY NOT EXTEND COMPLETELY THROUGH THE DRIVE LUG**

### 3. Installation Instructions

#### 3.1 *Propeller and Spinner Installation*

The Whirl Wind 300 Series propeller comes with a composite spinner, forward bulkhead, and back-plate.

**WARNING! DO NOT OPERATE THE ENGINE / PROPELLER WITH ONLY THE SPINNER FAIRINGS INSTALLED!**

IF THE ENGINE AND PROPELLER ARE TO BE RUN WITHOUT THE SPINNER DOME INSTALLED, IT IS IMPARATIVE THAT THE FAIRINGS ALSO BE REMOVED. The centrifugal force will damage or destroy the fairings without the support of the spinner dome.

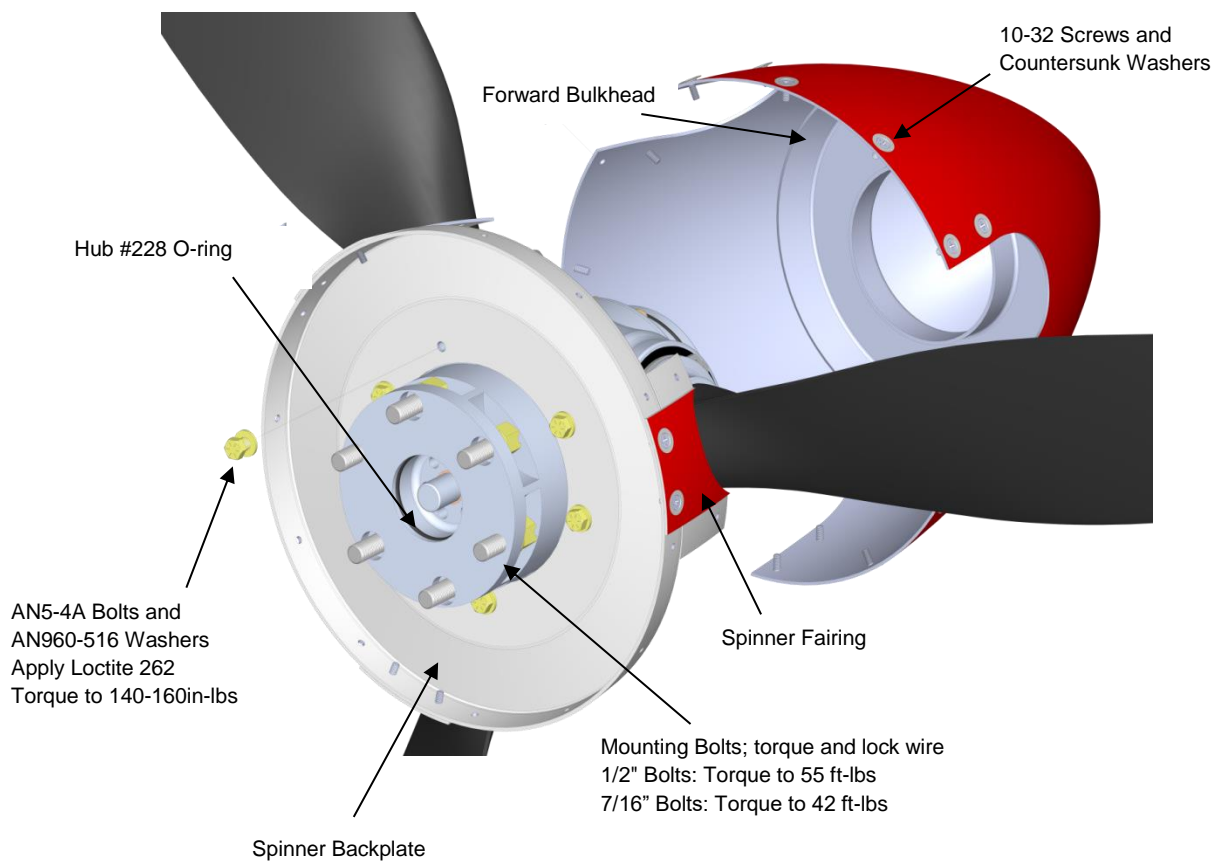

**Figure 3. Spinner Assembly**

1. **Spinner Back-Plate:** The spinner back-plate must be positioned on the hub such that the spinner dome blade cutouts can line up with the blades (see Figure 3). The spinner and back-plate have been number or letter coordinated to match the blade cutout openings. Place a washer on each of the 5/16" AN5-4A bolts and install the back-plate on the hub so the back plate flange cups away from the blades. Torque the bolts to 160in-lbs.
2. **Spinner Dome:** Install the spinner dome onto the propeller hub and rear bulkhead. The spinner and spinner rear bulkhead have been number or letter coordinated to match the blade cutout openings. Fasten the spinner dome and blade Fairings to the rear bulkhead using the supplied 10-32 screws and Countersunk washers.



**NOTE:** Before beginning installation of the 300 Series propeller system inspect the O-Ring located in the propeller hub flange and make sure the O-Ring is in good condition. **Cleaning the hub and propeller flange with WD-40 or equivalent** is recommended.

3. **Propeller System:** After lightly lubricating the O-Ring with clean engine oil or O-Ring lube, carefully install the propeller on the engine crankshaft by tightening the (6) propeller bolts.

***Warning!*** To avoid severe damage to the hub, when tightening the propeller bolts insure that the face of the prop hub is kept parallel with the face of the flywheel. In most cases this will require tightening the propeller bolts a little at a time in an alternating pattern. This may be easiest to do by tightening the bolts by hand until the hub contacts the flywheel. Bolt breakage WILL occur if there is a gap between the propeller hub, and the engine flange

- Using a calibrated torque wrench:

- Torque the **propeller hub mounting bolts**

**O-320 Engine with 7/16" bolts to 42 ft-lbs.** in the Following Increments 50%, 75% and Full Torque. Tighten each bolt 1/8 to 1/4 turn at a time.

**O-320/360/390 Engine with 1/2" bolts to 55 ft-lbs.** in the Following Increments 50%, 75% and Full Torque. Tighten each bolt 1/8 to 1/4 turn at a time.

- Torque the **AN5-4A rear bulkhead mounting bolts to 140-160 in-lbs.** in the Following Increments 50%, 75% and Full Torque. Tighten each bolt 1/8 to 1/4 turn at a time.

***Important!*** these values are for dry / non-lubricated bolts.

- Safety wire the prop bolts in pairs with 0.032" stainless safety wire after installation.

***IMPORTANT!*** After first installation run the propeller for 5 min at 50% RPM. Then verify that the spinner screws are tight during the first few hours of operation.

### 3.2 Governor Installation

- Clean governor and engine-governor mating surfaces.
- Place gasket on governor side.
- Align governor spline to engine drive and push governor up to seat against engine drive pad.
- Install governor mounting hardware and torque to 180 in-lbs.
- Attach control cable to the governor control arm with the appropriate hardware.

***Note:*** The control arm is spring loaded to high RPM. Make sure control arm moves freely through 45 degrees of travel.

***WARNING!*** Governor MAXIMUM pressure relief is 330 psi! Recommended governor model is Jihostroj P-920-032/A with 310 to 330 psi pressure relief valve.

## 4. Inspections and Operation

**WARNING!** Operation of this propeller over maximum RPM is strictly prohibited and may result in a catastrophic structural failure of the propeller system. Any type of structural failure may result in death or severe bodily injury. Refer to your propeller data sheet for Maximum RPM.

**NOTE:** For safety reasons always turn the propeller opposite of the usual direction of rotation.

Be sure to limit engine power settings when performing ground run-up. Engine and propeller manufacturers do NOT recommend high engine power settings on the ground because it can result in excessive engine temperatures and propeller blade foreign object damage.

It is recommended that the operator apply a high quality paste wax on glossy finish blades at least once a month to aide in protection from the elements. It is important that the blades are always sealed from outside moisture. Automotive materials such as Acrylithane paint and Epoxy resin can be used to fix small scratches and chips.

### 4.1 *First Run-Up*

To ensure proper first run-up of your new Whirl Wind 300 Series propeller system, refer to your engine's operation manual for the proper run-up power setting. At the proper run-up power setting pull the propeller control lever back until the RPM drops by 300 - 400 RPM. Push the propeller control lever forward and observe RPM increase. Cycle the pitch three times to purge air out of the system. After first run-up refer to "Section 5.2" for inspection.

**NOTE:** Static full throttle RPM should be approximately 2550. If it is not, you may need to adjust the low angle stop shown in Figure 4 on the following page.

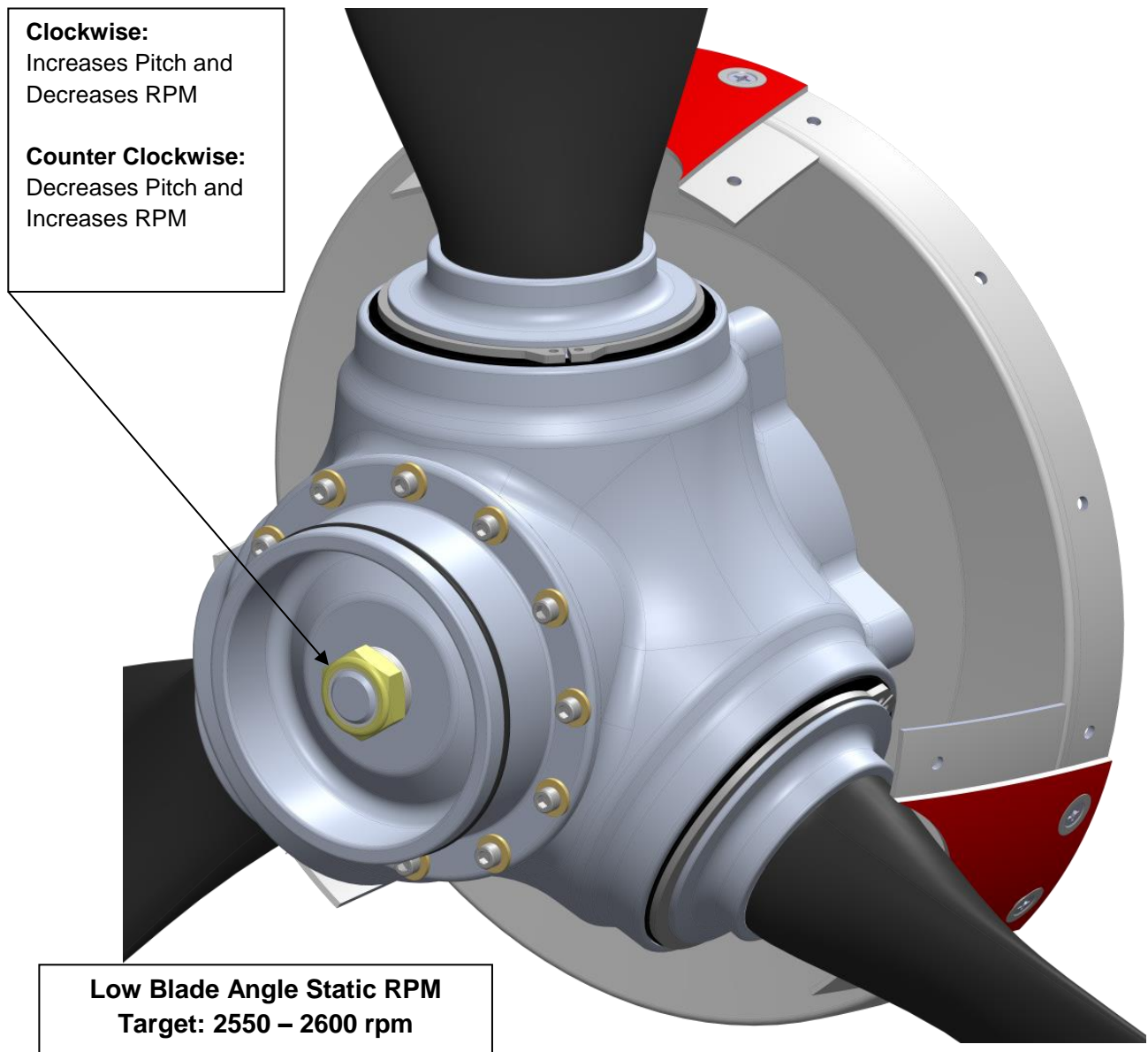

**Figure 4. Low Angle Stop Adjustment**

### **Inspection After First Run-Up**

1. Inspect the propeller system blades and spinner for any nicks, cracks, or chips.
2. Inspect each aluminum blade ferrule and blade intersection (located at the root end of blade where the silicone sealant is visible) for movement and/or signs of chafing. There should be no movement between aluminum ferrule and blade. Notify Whirl Wind Propellers immediately if movement is detected.
3. Gently shake each propeller blade to feel for blade movement in the hub. Blade shake movement is allowed up to 1/8 inch, measured from the tip. Radial play of up to 2 degrees is acceptable. If the check shows values above these tolerances, contact Whirl Wind Propellers immediately. Movement is only allowed between the aluminum blade ferrule and the propeller hub, not as described in item #2 above.
4. Inspect the nickel leading edge erosion shield. The nickel erosion shield should not be loose or have any cracks. Small paint cracks parallel to and along the edge of the shield where the nickel and paint meet are acceptable.

5. Check spinner dome and the aft and forward bulkheads for cracks of any kind or looseness.
6. No grease or oil leaks should be detected. NOTE: A small amount of grease leakage may occur in new propellers (first 2 to 5 hours) or in hot climates with high RPM conditions.
7. Before every flight the prop-control should be cycled at least twice to circulate the engine oil. In cruise flight any number of RPM settings are possible within engine and propeller limitations. The RPM restrictions from the engine and propeller manufacturers must be strictly observed.

**NOTE:** Your Whirl Wind Propeller System has been statically balanced at the factory. However, it is recommended to have the engine/propeller dynamically balanced before the first flight.

Repeat the same inspection after balancing as for first run-up. All engine RPM and power settings limitations must be followed when operating the Whirl Wind 300 Series propeller. Refer to your Whirl Wind propeller data sheet for propeller operation limitations.

## 4.2 Over-speed Warning

Propeller RPM Limit: 2700 rpm

It is possible to over-speed the propeller by rapid throttle advancement. Therefore, always adjust the power and RPM lever slowly and smoothly to avoid the possibility of over-speed.

**NOTE:** If loss of oil pressure or governor failure, propeller over-speed will occur. Immediately retard the throttle and reduce aircraft airspeed if this occurs.

### If an over-speed occurs:

Over-speed Occurrence	Required Action
up to 110 % of the max RPM	A 50 hours inspection must be performed immediately by a certified A&P mechanic
111% to 120% of the max RPM	A mandatory teardown inspection at the factory is required
above 121% of the max RPM	<b><u>No further use of the propeller is permitted!</u></b> The propeller must be returned to the factory for inspection.

**WARNING!:** Failure to adhere to these guidelines may lead to a catastrophic propeller structural failure. Any type of structural failure may result in death or severe bodily injury.

### 4.3 Dynamic Balancing

Your Whirl Wind Propeller System has been statically balanced at the factory. Dynamic balancing is recommended after installing or performing maintenance on a propeller. While this is normally an optional task, it may be required by the engine or airframe manufacturer to make certain the propeller/engine combination is balanced properly before operation. Some engine companies consider vibration levels above 1.5 in/s to be dangerous, but this is not a structural concern for the propeller. Vibrations may be uncomfortable anywhere above about 0.25 in/s. Repeat the same inspection after balancing as for first run-up.

### 4.4 Blade Tracking

For continued airworthiness, blades should track within 1/4". Rotating the blade opposite to the direction of engine rotation, point one blade straight down. Tape a piece of paper on a flat surface directly under the blade (may need to raise the paper by stacking wood underneath until it almost touches the tip and you can trace a line along the tip). Trace a line on the paper following one side of the blade tip and repeat for each other blade. The lines should be within 1/4" of each other.

### 4.5 Preflight Check

1. Inspect the propeller system blades and spinner for any nicks, cracks, or visible delaminations.
2. Inspect each blade's aluminum ferrule and blade intersection (located at the root end of blade where the silicone sealant is visible) for movement and/or signs of chafing. There should be no movement between aluminum ferrule and blade. Notify Whirl Wind Propellers immediately if movement is detected.
3. Gently shake each propeller blade to feel for blade movement in the hub. Blade shake movement is allowed up to 1/8 inch, measured from the tip. Radial play of up to 2 degrees is acceptable. If the check shows values above these tolerances, contact Whirl Wind Propellers immediately. Movement is only allowed between the aluminum blade ferrule and the propeller hub, not between the composite blade and the ferrule.
4. Inspect the nickel leading edge erosion shield. The nickel erosion shield should not be loose or have any cracks. Small paint cracks parallel to and along the edge of the shield where the nickel and paint meet are acceptable.
5. Check spinner dome and the aft and forward bulkheads for cracks of any kind or looseness.
6. No grease or oil leaks should be detected. **NOTE:** A small amount of grease leakage may occur in new propellers (first 2 to 5 hours) or in hot climates with high RPM conditions.
7. Before every flight, the prop-control should be cycled at least twice to circulate the engine oil. In cruise flight, any number of RPM settings are possible within engine and propeller limitations. The RPM restrictions from the engine and propeller manufacturers must be strictly observed.

### 4.6 First Flight

1. Installation (pg. 8) and Preflight (pg. 13) procedures should be reviewed for missed/improper steps (verify all torque specs, Loctite, and safety wire are utilized where applicable on propeller and spinner).
2. Perform first flight approximately 20 min over the airport. Take notice of vibration & propeller RPM control.
3. Set first take off RPM to 2500, this will give a buffer for an unexpected RPM increase.
4. Slowly increase operation envelope to check RPM control. Ex: full throttle at Vy yields 2700 RPM, same with full throttle straight and level. Set cruise MAP and check RPM range from 2700 to 2200. **NEVER operate the propeller over 2700 RPM!**
5. After first flight, remove the spinner and inspect the propeller as per the 50 hr. inspection in Section 4.7.

## **4.7 50-Hour Inspection**

1. **BLADES:** Inspect the propeller system blades for any nicks, cracks, or delaminations. Inspect blades for cracks in the composite skins and nickel leading edges. No cracks are allowed in either. If cracks are present return propeller for repair to a Whirl Wind Propellers service center.
  - a. Inspect the cambered side of each blade for chord-wise cracks and the entire blade for any delamination of the composite skin or obvious discoloration.
  - b. Small cracks parallel along the nickel edge are allowed as long as the leading edge is not loose. Scratches or chips should be sealed up as soon as practicable.
  - c. Tap Test: using a quarter, tap along the length of the blade and leading edge, listening for any sudden hollow sound (delamination). Note that the pitch is expected to change abruptly chord-wise, but not length-wise.
2. **BLADE FERRULES:** Inspect each aluminum blade ferrule and blade intersection (located at the root end of blade where the silicone sealant is visible) for movement and/or signs of chafing. Gently flex the blade at the tip to check for any movement between the aluminum ferrule and blade root. No movement is allowed. There should be no movement between aluminum ferrule and blade. Notify Whirl Wind Propellers immediately if movement is detected.
3. **BLADE MOVEMENT:** Gently shake each propeller blade to feel for blade movement in the hub. Blade shake movement is allowed up to 1/4 inch, measured from the tip. Radial (change in blade angle) play of up to 0.5 degrees is acceptable. Movement is only allowed between the aluminum ferrule and the propeller hub, not between the composite blade and the ferrule.
4. **LEADING EDGE:** Inspect the nickel leading edge erosion shield. The nickel erosion shield should not be loose or have any cracks. Small paint cracks parallel to and along the edge of the shield where the nickel and paint meet are acceptable.
5. **SPINNER:** Remove spinner and check for nicks, cracks or chips. Check spinner dome and the aft and forward bulkheads for cracks of any kind or looseness. Also inspect for any signs of chafing.
  - a. Ensure secure attachment to the hub.
  - b. Check 5/16" bolts on aft bulkhead for tightness
6. **GREASE:** No grease or oil leaks should be detected. NOTE: A small amount of grease leakage may occur in new propellers or in hot climates with high RPM conditions.
7. **FLANGE BOLTS:** Check mounting bolts for torque (see Figure 3 on page 8.)
8. Before every flight the prop-control should be cycled at least twice to circulate the engine oil.

## **4.8 Teardown Inspection**

Because of how new this propeller system is, the teardown inspection interval is 5 years/500 hrs. You may call Whirl Wind Propellers to check for updates on this inspection interval to see when it increases. Send your propeller system to an approved Whirl Wind shop to perform the inspection or request that we send our manual to another propeller shop.

## **5. Vibrations and Troubleshooting**

Experimental aircraft may operate with unapproved engines or propellers or engine modifications to increase horsepower, such as unapproved crankshaft damper configurations or high compression pistons. These issues affect the vibration output of the engine and the stress levels on the propeller. Significant propeller life reduction and failure are real possibilities. Frequent inspections are strongly recommended if operating with a non-certificated installation; however, these inspections may not guarantee propeller reliability, as a failing device may be hidden from the view of the inspector. Propeller overhaul is strongly recommended to accomplish periodic internal inspection.

Your Whirl Wind propeller system has been statically balanced at the factory. Dynamic balancing is recommended after installing or performing maintenance on a propeller. While this is normally an optional task, it may be required by the engine or airframe manufacturer to make certain the propeller/engine combination is balanced properly before operation. Some engine companies consider vibration levels above 1.5 in/s to be dangerous, but this is not a structural concern for the propeller. Vibrations may be uncomfortable anywhere above about 0.25 in/s. Repeat the same inspection after balancing as for first run-up.

Vibration problems because of propeller system imbalance are normally felt throughout the rpm range, with the intensity of vibration increasing with rpm. Vibration problems that occur in a narrow rpm range are a symptom of resonance. If a resonance related vibration is rough and is not remedied by dynamic balancing, you may need to send in your propeller for inspection; first follow these checks:

- (a) Control surfaces, cowl flaps, exhaust system, landing gear doors, etc. for excessive play that may be causing vibration unrelated to the propeller
- (b) Engine mount wear
- (c) Proper engine/propeller flange mating
- (d) Blade track: within 0.25"
- (e) Blade angles: within 0.5° of each other

## 6. Transfer of Ownership

Please complete this form upon transfer of ownership and return to:

Whirl Wind Propellers Corp  
1800 Joe Crosson Drive, Ste C  
El Cajon, CA 92020

Or by email to:

wwpc@whirlwindpropellers.com

Propeller Model: 300( )- - / - - -

Hub SN: \_\_\_\_\_ Blade 1 SN: \_\_\_\_\_

Blade 2 SN: \_\_\_\_\_ Blade 3 SN: \_\_\_\_\_

Manufacture Date: \_\_\_\_\_

Date Transferred: \_\_\_\_\_

### **Original Owner**

Name: \_\_\_\_\_

Address: \_\_\_\_\_

City, State, Zip: \_\_\_\_\_

Phone Number: \_\_\_\_\_

Notes: \_\_\_\_\_

### **New Owner**

Name: \_\_\_\_\_

Address: \_\_\_\_\_

City, State, Zip: \_\_\_\_\_

Phone Number: \_\_\_\_\_

Notes: \_\_\_\_\_



## 7. Limited Warranty

We hope you enjoy your new Whirl Wind composite propeller. We have worked hard to ensure that your propeller will meet or exceed your expectations for years to come.

We offer a one year limited warranty (the "Warranty Period") on any defect in materials and workmanship.

In the event a unit does not conform to this express warranty during the Warranty Period, Whirl Wind Propellers Corporation (WWPC) will repair or replace the defective material at its place of business at San Diego, CA, USA. Whirl Wind Propellers will decide at its sole discretion which remedy, repair or replacement, it will provide. Any replacement of a unit or a part of a unit during the Warranty Period will not extend the Warranty beyond the original duration. The remedy of repair or replacement is exclusive and does not include the cost of shipping, removal, or installation, all of which are the customer's responsibility.

### **Procedure for Obtaining Warranty Service**

Units or parts that are defective must be shipped prepaid to Whirl Wind Propellers at the address listed on page 1. The unit must be accompanied by a copy of the original (Distributor or Dealer) invoice, a Return Authorization Number (which can be obtained by phoning or emailing Whirl Wind Propellers), and a brief description of the defect.

### **Conditions, Exclusions, and Disclaimers**

This limited warranty applies only to units that have been installed, used, and maintained properly in strict accordance with our specifications, instructions, and recommendations. It does not cover units that show abuse, alterations, improper installation, improper maintenance or repair, or improper packaging for shipment; and it does not pertain to damage due to object strike, or excessive blade wear due to operation. Racing use of any kind automatically voids this Warranty. The use of units on or with engines or equipment not approved by WWPC automatically voids this warranty. For purposes of this limited warranty, "engines or equipment not approved

by WWPC shall mean engines or equipment that are not explicitly consistent with all specifications and instructions applicable to that engine or equipment, including, without limitation, those established by the Federal Aviation Administration, those established by the manufacturers of any component parts used in connection with the units, and/or those established by WWPC. The purchaser has sole responsibility for ensuring that the use of the units is in compliance with all applicable specifications and instructions, and no conduct by WWPC shall prevent this Warranty from being voided for failure to comply with the instructions or specifications provided by any third-party.

This Limited Warranty is the only warranty provided with respect to covered units, and *there are no other warranties, representations, conditions or guarantees, express or implied, with respect to the covered units or the manufacture thereof, including, without limitation, any implied warranties of merchantability or fitness for a particular purpose.*

Repair or replacement of a nonconforming unit or part is the exclusive remedy for breach of this limited warranty, and shall constitute fulfillment of all liabilities of WWPC to a customer or user, whether based on contract, negligence or otherwise. IN NO EVENT SHALL WHIRL WIND PROPELLERS CORPORATION BE LIABLE FOR ANY OTHER EXPENSES, CLAIMS OR DAMAGES OF ANY KIND HOWSOEVER CAUSED, INCLUDING (WITHOUT LIMITATION) ANY OTHER PRODUCT REPLACEMENT OR INSTALLATION COSTS AND/OR ANY DIRECT, INDIRECT, CONSEQUENTIAL, INCIDENTAL OR SPECIAL DAMAGES.

The purchaser of the covered units has read, understood and, by purchasing the units, agrees to be bound by the above terms and conditions. Some states do not allow the exclusion of incidental or consequential damages, so the above limitations may not apply to you.

This Warranty gives you specific legal rights and you may also have other rights which vary from state to state.

## 8. Propeller Log Book

1. Proper maintenance of this logbook is the owner's responsibility. It is an important record designed for the owner's information and protection.
2. If the propeller is sold or installed on another aircraft the logbook should be transferred with the propeller. New owner information should be registered with Whirl Wind Propellers by calling 619-562-3725.
3. It is recommended that maintenance release tags and work orders be attached inside the back cover of this book. If a copy of the work order is not available the repair station and work order numbers should be referenced in the logbook entry.

<b>Model:</b>	300-3B( )- / - -S-R
<b>Hub SN:</b>	
<b>Blade SN's:</b>	
<b>Manufacture Date:</b>	

Date:	Total Propeller Time:	Time Since Last Overhaul:	Repairman Certificate Number:
Description of Work:			
Date:	Total Propeller Time:	Time Since Last Overhaul:	Repairman Certificate Number:
Description of Work:			
Date:	Total Propeller Time:	Time Since Last Overhaul:	Repairman Certificate Number:
Description of Work:			
Date:	Total Propeller Time:	Time Since Last Overhaul:	Repairman Certificate Number:
Description of Work:			

Description of Work:

---

Date:	Total Propeller Time:	Time Since Last Overhaul:	Repairman Certificate Number:
Description of Work:			
<hr/>			
Date:	Total Propeller Time:	Time Since Last Overhaul:	Repairman Certificate Number:
Description of Work:			
<hr/>			
Date:	Total Propeller Time:	Time Since Last Overhaul:	Repairman Certificate Number:
Description of Work:			
<hr/>			
Date:	Total Propeller Time:	Time Since Last Overhaul:	Repairman Certificate Number:
Description of Work:			
<hr/>			
Date:	Total Propeller Time:	Time Since Last Overhaul:	Repairman Certificate Number:
Description of Work:			
<hr/>			

Date:	Total Propeller Time:	Time Since Last Overhaul:	Repairman Certificate Number:
Description of Work:			
Date:	Total Propeller Time:	Time Since Last Overhaul:	Repairman Certificate Number:
Description of Work:			
Date:	Total Propeller Time:	Time Since Last Overhaul:	Repairman Certificate Number:
Description of Work:			
Date:	Total Propeller Time:	Time Since Last Overhaul:	Repairman Certificate Number:
Description of Work:			
*****			
Photo-Copy next page if more maintenance is expected			

Date:	Total Propeller Time:	Time Since Last Overhaul:	Repairman Certificate Number:
Description of Work:			
<hr/>			
Date:	Total Propeller Time:	Time Since Last Overhaul:	Repairman Certificate Number:
Description of Work:			
<hr/>			
Date:	Total Propeller Time:	Time Since Last Overhaul:	Repairman Certificate Number:
Description of Work:			
<hr/>			
Date:	Total Propeller Time:	Time Since Last Overhaul:	Repairman Certificate Number:
Description of Work:			
<hr/>			
Date:	Total Propeller Time:	Time Since Last Overhaul:	Repairman Certificate Number:
Description of Work:			
<hr/>			